

# UNIMATIC

MADE TO ORDER/  
PRIVATE COMMISSION

# 01 OUR WORLD

## ENTER OUR WORLD

UNIMATIC has always welcomed customization requests that lead to special projects, whether for individual pieces or small series.

You'll have the opportunity to make your watch truly unique, with the support of our experts throughout every stage of the process.

Thanks to a well-established design language developed over the years and the quality of our processes, the core features will remain consistent with all UNIMATIC products, each individually tested for accuracy and water resistance up to 600 meters, ensured by the use of premium materials such as sapphire crystal and meticulous craftsmanship.

You'll be able to choose colors, textures, materials, and engravings, creating a timepiece that combines UNIMATIC's unmistakable aesthetic with your personal preferences.



# THE CASES 2

## THE STARTING POINT

The first step is choosing the case from the five available options. Each model represents a different facet of UNIMATIC's identity and is best suited to specific contexts and uses.

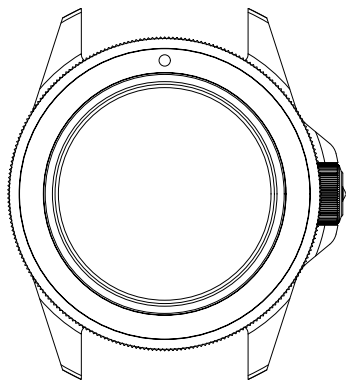

MODELLO UNO

Diver watch

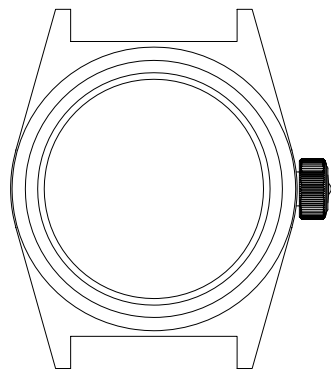

MODELLO DUE

Field watch

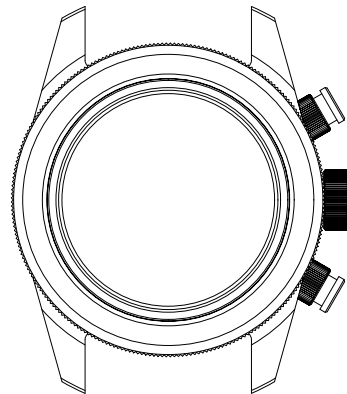

MODELLO TRE

Chrono watch

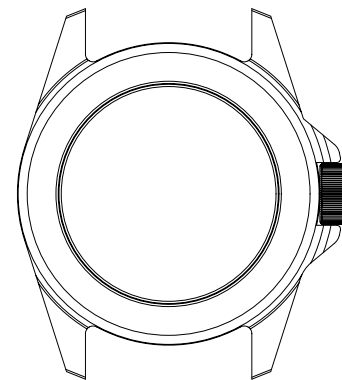

MODELLO QUATTRO

Military watch

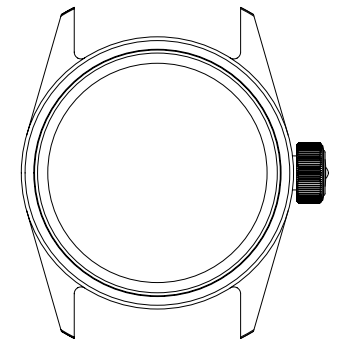

MODELLO CINQUE

All-round watch

# MODELLO UNO

## DIVER WATCH



The diver watch, in a minimalist guise, combines the best of iconic vintage pieces within an elegant 40mm case.

Thanks to its 41.5mm unidirectional rotating bezel, which slightly protrudes for optimal grip, it's easy to track dive time or any other activity by aligning the marker with the minute hand.

- **Made in Italy**
- **Up to 600m≈2000ft≈60atm**
- Diameter 40mm case, 41.5mm with bezel
- 120 clicks mono-directional security bezel
- 2.5mm thick double domed sapphire
- **Inner-side anti-reflective coating**
- **Super-LumiNova® indexes**
- **UNIMATIC tough case**
- **Warranty card with unique ID seal**

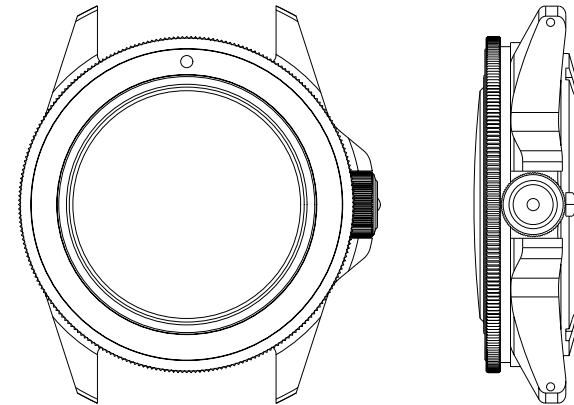

# MODELLO DUE

## FIELD WATCH



Our field watch features a uniquely designed 38.5mm case that blends modern lines with vintage appeal.

The double-domed sapphire crystal, a standout element in the side profile, gives the watch an unexpected presence on the wrist for such a compact model, combining robustness and character without sacrificing elegance.

- Made in Italy
- 300m≈1000ft≈30atm
- Diameter 38mm
- 2.7mm thick ultra double domed sapphire
- Inner-side anti-reflective coating
- Super-LumiNova® indexes
- UNIMATIC tough case
- Warranty card with unique ID seal

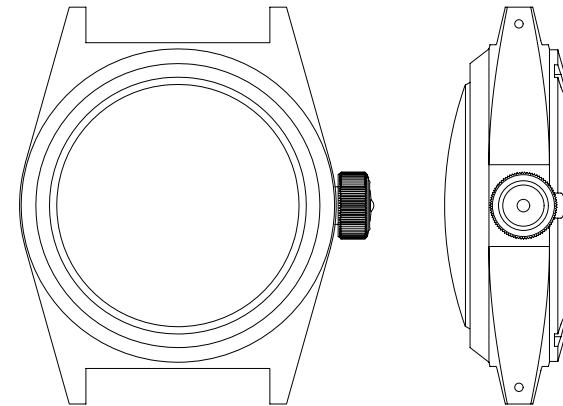

# MODELLO TRE

## CHRONO WATCH



Our Chronodiver watch retains the spirit and dimensions of the Modello Uno, featuring a 40mm case topped with a 41.5mm unidirectional rotating bezel.

The oversized pushers are equipped with two small screw-down crowns that seal the case up to 30 bar of pressure. Once unscrewed, they allow precise operation of the chronograph to 1/5 of a second, with a minute counter on the sub-dial.

- **Made in Italy**
- **300m≈1000ft≈30atm**
- Diameter 40mm case, 41.5mm with bezel
- 2.5mm thick double domed sapphire
- 120 clicks mono-directional security bezel
- **Inner-side anti-reflective coating**
- **Super-LumiNova® indexes**
- 1/5 sec sweep second hand with mechanical reset
- **UNIMATIC tough case**
- **Warranty card with unique ID seal**

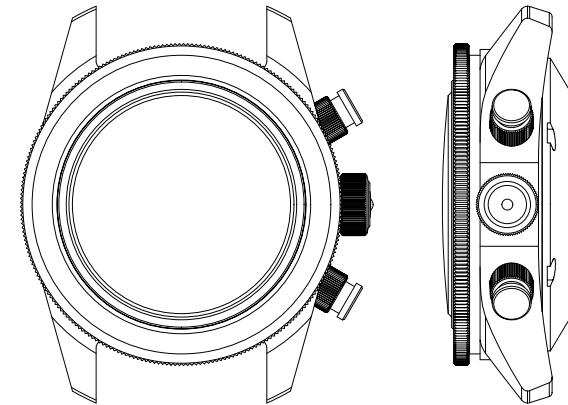

# MODELLO QUATTRO

## MILITARY WATCH



The functional inspiration behind every UNIMATIC project finds its most radical expression in our interpretation of the military watch: the Modello Quattro.

The key design element is its 40mm case, built with bold, solid volumes in a compact diameter. The large fixed bezel and the grooved detail beneath it enhance the iconic features of a classic military timepiece.

- Made in Italy
- 300m≈1000ft≈30atm
- Diameter 40mm
- 2.8mm thick flat sapphire
- Inner-side anti-reflective coating
- Super-LumiNova® indexes
- UNIMATIC tough case
- Warranty card with unique ID seal

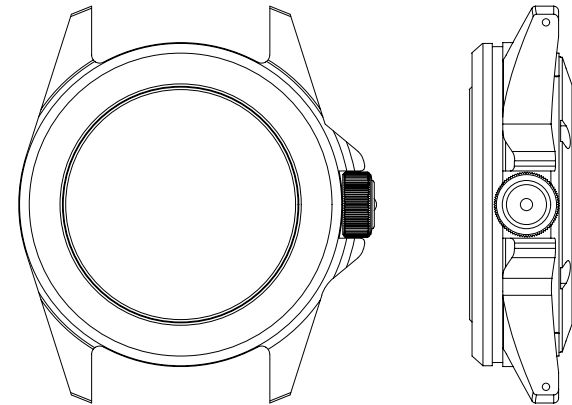

# MODELLO CINQUE

ALL-ROUND WATCH



With a 36mm case diameter, the Modello Cinque is the most compact of the five families.

It fits perfectly even on slimmer wrists and, thanks to its wide dial opening, larger than the UNIMATIC collection average, and the case's angled rehaut, it ensures excellent legibility and a strong wrist presence. The curved lug profile comfortably wraps around most wrists.

- Made in Italy
- 300m≈1000ft≈30atm
- Diameter 36mm
- 2.2mm thick double domed sapphire
- Inner-side anti-reflective coating
- Super-LumiNova® indexes
- UNIMATIC tough case
- Warranty card with unique ID seal

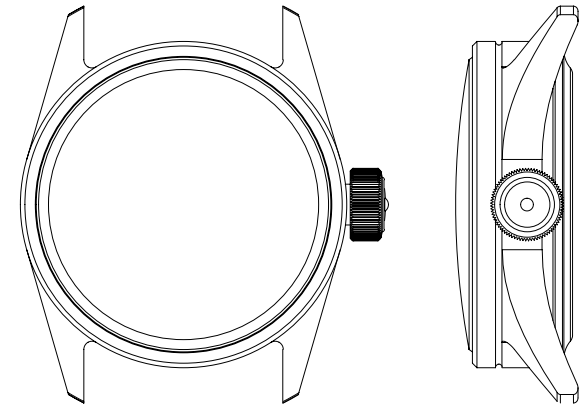

# THE MATERIALS 03

Over time, we have explored and selected materials that reflect our vision of strength and durability. That's why today you can choose from stainless steel, titanium, bronze, forged carbon, and solid gold.

## 01 . STAINLESS STEEL

The most commonly used material in the production of UNIMATIC watches is 316L stainless steel: in addition to its high mechanical performance, the molybdenum alloy provides improved corrosion resistance and excellent hypoallergenic properties.



## 02 . TITANIUM

The Grade II titanium used by UNIMATIC has a specific weight that is 41% lower than steel, ensuring excellent technical performance in mechanical and chemical resistance. This metal has a darker and warmer color, and due to its lower heat transmittance, it also feels less cold to the touch.



## 03 . PURE BRONZE

The UNIMATIC bronze cases are crafted from pure, untreated alloy. Initially, they exhibit a uniform golden color and are subject to rapid oxidation, which creates a unique patina on each piece, that will stabilize into warm brown tones. These cases feature a titanium case back, making them hypoallergenic and more comfortable.



# THE MATERIALS 3

## 04 . FORGED CARBON

Forged carbon is processed using C.N.C. techniques and offers extraordinary mechanical characteristics and weight, which is reduced by 62% compared to the same part in steel. It features a marbled and always unique finish, created by the random arrangement of the fibers in the material.



## 05 . SOLID GOLD

The UNIMATIC gold cases are CNC-machined from an 18k solid gold block. Even our precious metal references guarantee water resistance up to 30 bar/300M. This is achieved by incorporating a stainless steel cylindrical case that ensures watertight seals for the lens, crown, and caseback threads.



# THE FINISH 04

The case finish plays a key role in defining the watch's aesthetic. That's why you can choose between a brushed or sandblasted surface.

## 01. BRUSHED

Brushing is the most common finish for UNIMATIC products, performed by carefully orienting the brushes according to the specific surface of the case to be finished. It can also be alternated with a polished finish to create light effects on the volumes of the case.



## 02. SANDBLASTED

Sandblasting, performed through precise pressure blasting of abrasive materials, gives the metal surface a finely textured and semi-matte finish, on which light settles softly and gradually. It can be completed with a colored surface coating such as Cerakote®, or DLC.



# THE COATING 03 5

Finally, the case can optionally be customized with a black DLC coating or, alternatively, with a Cerakote treatment available in a wide range of colors.

## 01. CERAKOTE

Cerakote® is a special spray-applied and heat-cured polymer-ceramic coating. Cerakote® ceramic coatings offer a protective and durable finish in a wide range of colors and gloss levels, resistant to weather, acids, corrosion, and scratches. This coating gives each piece an individual and unique wear pattern.



## 02. CERAKOTE STONEWASHED

It is a mechanical process based on vibratory tumbling of the finished components. It creates a semi-matte surface finish with an irregular pattern that varies from piece to piece. This treatment gives a sophisticated worn look and can be applied both to bare metal and after a surface coating, as seen in our Cerakote® coated productions.



## 03. DLC

The DLC coating is a high-tech surface finish performed under vacuum by evaporation. DLC stands for Diamond-Like Carbon and refers to carbon, with a structure similar to diamond, that is evaporated during the process. It blackens the surface of the watch and boasts extremely high scratch resistance (Up to 900 Vickers).



# THE MOVEMENT 6

A WIDE SELECTION

Depending on your needs and intended use, you can choose from different types of movements.



## MOVEMENTS FEATURES

6

MOVEMENT	MANUFACTURER	POWER SUPPLY	ADDITIONAL FUNCTIONS	POWER RESERVE
VH31A	TMI Seiko	Quartz	-	≈2 years
RONDA 515.24	Ronda	Quartz	GMT window Date	≈45 months
VK64	TMI Seiko	Meca-Quartz	Chrono Chrono minutes 24h indicator Date	≈3 years
NH35	TMI Seiko	Automatic winding	Date	More than 41 hours
NH34	TMI Seiko	Automatic winding	GMT Date	More than 41 hours
SELLITA SW 200	Sellita	Automatic winding	Date	Minmum 38h Typical 41h
ETA 2893	ETA	Automatic winding	GMT Date	42 hours
SW 510	Sellita	Automatic winding	Chrono Date	Minmum 56h Typical 62h

# UNIMATIC

MODELLO UNO

MODELLO DUE

MODELLO TRE

MODELLO QUATTRO

MODELLO CINQUE

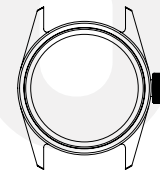
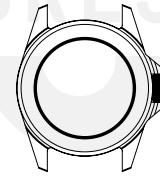
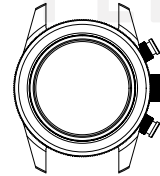
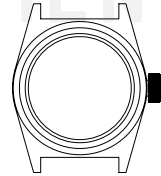
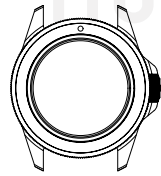







MOVEMENT	DESCRIPTION					
VH31	Quartz Japan	✓	✓		✓	✓
RONDA 515.24	Quartz Swiss	✓	✓		✓	✓
VK64	Meca-Quartz Japan			✓		
NH35	Automatic Japan	✓	✓		✓	
NH34	Automatic GMT Japan	✓	✓		✓	
SELLITA SW 200	Automatic Swiss	✓	✓		✓	✓
ETA 2893	Automatic GMT Swiss	✓	✓		✓	✓
SW 510	Automatic chrono Swiss			✓		✓

# 07 A POP OF COLOR

## WHAT CAN I CUSTOMIZE?

Any dial color you can imagine can be created, with the option to pair it with a Super-LumiNova® pigment chosen for the hands and indices.

UNIMATIC's ongoing research and experimentation also lead us to consider textured dial proposals, which we strive to bring to life in the best possible way.

-  CASE: material, finish, engraving
-  DIAL BASE: color, texture, logo
-  BEZEL INSERT
-  HANDS: base color, tip color
-  SUPER-LUMINOVA® LUMINOUS
-  PRINTING



# FULL WATCH HEAD DEVELOPMENT



## HOW A MTO WATCH IS DEVELOPED?

Here comes an example of a made to order watch with a custom dial.  
The chosen features have been:

01. MODELLO UNO case
02. Forged carbon case material
03. Custom dial with customer's pattern
04. Printing and UNIMATIC logo at 6 in color PANTONE 2007C/GOL
05. Lume tracking with SUPER-LUMINOVA® GL OR LIGHT
06. Assembly of the dial
07. Matte black bezel with SUPER-LUMINOVA® GL OR LIGHT color dot
08. HANDS in color PANTONE 2007C/GOL and SUPER-LUMINOVA® GL OR LIGHT



# FULL WATCH HEAD DEVELOPMENT

07

Let's see the development step by step.

## 01 . BASE MODEL: MODELLO U1S

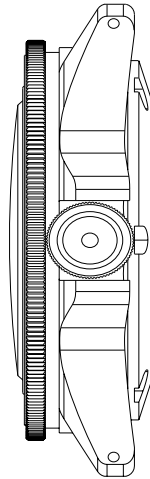

## 02 . CASE MATERIAL: FORGED CARBON





FULL WATCH HEAD DEVELOPMENT



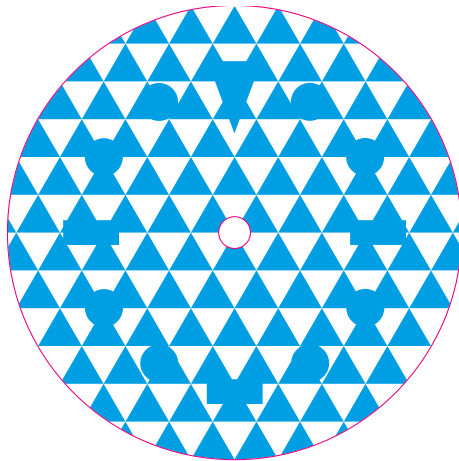



03 . DIAL BASE



-  DEEP ETCHING
-  CUT THROUGH



04 . DIAL PRINTING

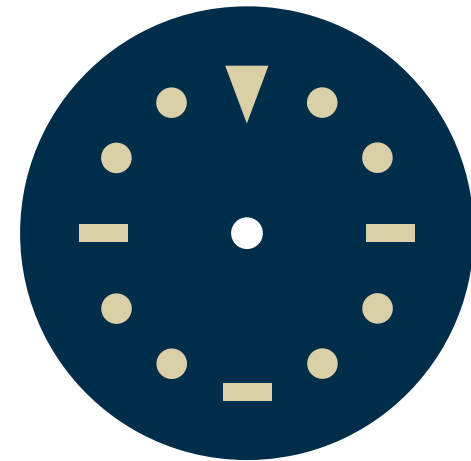

-  BASE COLOR: PANTONE 282C
-  PRINTING COLOR 2: SILVER
-  LUMINOVA COLOR: SUPER-LUMINOVA® GL OR LIGHT
-  PRINTING COLOR 1: PANTONE 2007C/ GOL

05 . DIAL LUME







-  BASE COLOR: PANTONE 282C
-  LUMINOVA COLOR: SUPER-LUMINOVA® GL OR LIGHT

FULL WATCH HEAD DEVELOPMENT

37



06 . FINISHED DIAL



-  BASE COLOR: PANTONE 282C
-  PRINTING COLOR 2: SILVER
-  LUMINOVA COLOR: SUPER-LUMINOVA® GL OR LIGHT
-  PRINTING COLOR 1: PANTONE 2007C/ GOL

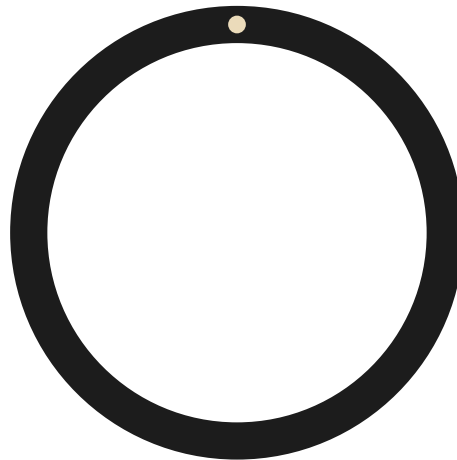

07 . INSERT

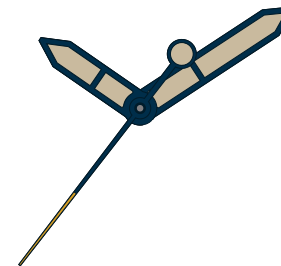

-  INSERT BASE: MATTE BLACK
-  LUMINOVA COLOR: SUPER-LUMINOVA® GL OR LIGHT

08 . HANDS SET



-  HANDS BASE: PANTONE 282C
-  LUMINOVA COLOR: SUPER-LUMINOVA® GL OR LIGHT
-  PRINTING COLOR 1: PANTONE 2007C/ GOL

# A QUIET PERSONAL TOUCH 38

## BRANDED DIAL ON AN EXISTING WATCH

Customizing your watch doesn't always require complex modifications: sometimes, the most effective solution can be printing your emblem, monogram or logo on the dial.

### 01. THE VECTOR

Here comes the example of our U1S-T-MP created in collaboration with the Fire Department of New York City.



### 02. THE ORIGINAL DIAL

You can choose the color and position of the logo, adapting it to the dial's color palette without compromising the overall balance of the design



### 03. THE FINAL DIAL

Here is the example of the final customized dial.



### 04. THE FINAL RESULT

Here is the example of the final customized dial.



# YOUR MARK IN STEEL 9

## YOUR LOGO ON THE CASEBACK

The case back is an element of the watch to which UNIMATIC always pays great attention, offering a selection of engravings that match the character of the model. Whether it's a logo, a symbol, or a phrase, we're ready to engrave your idea on the case back of your watch.



**MODELLO UNO**  
Diver watch

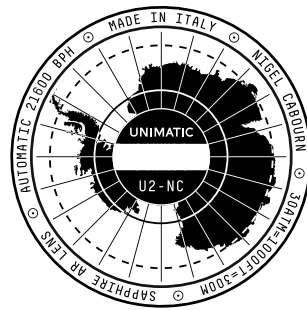

**MODELLO DUE**  
Field watch

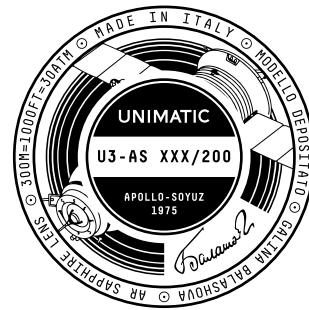

**MODELLO TRE**  
Chrono watch



**MODELLO QUATTRO**  
Military watch

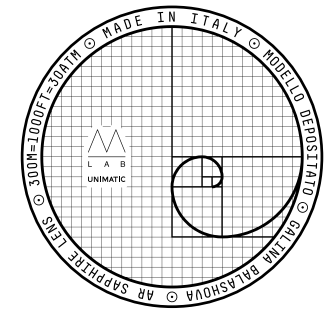

**MODELLO CINQUE**  
All-round watch



# 10 TO COMPLETE: THE STRAP

## COMPLETE YOUR WATCH

The final touch is the choice of the strap, to be selected from the many available models, differing in color, shape, and material (including leather, TPU, nylon, Cordura, and steel).

You can find all our options in the link down below:

[www.unimaticwatches.com/accessories/straps/](http://www.unimaticwatches.com/accessories/straps/)



# 1 THE PRODUCT SET

All our watches come in a unique tough case that can be customized in the outer tag and the warranty card.

